

# SLIDING PLATES 7.21

12 MM THICK  
ACC. TO VDI 3357

Sinter ident no.	L1 ± 0.2	b1	s -0.02	L2 ± 0.2	L3 ± 0.2	L4 ± 0.2	L5 ± 0.2	b2 ± 0.2	Shape	Cyl. screw DIN EN ISO 4762	Pc.
63775	160	25	12	25	135	-			A	M8 x 25	2
63776	200				175	225			B		3
63777	250				125	225			B		3
63778	80	55			225	B			3		
63779	100	75			225	B			3		
63780	125	100			225	B			3		
63781	160	135			225	B			3		
63782	200	175			225	B			3		
63783	250	225			225	B			3		
63784	300	275			225	B			3		
63785	80	55			225	B			3		
63786	100	75			225	B			3		
63787	125	100	225	B	3						
63788	160	135	225	B	3						
63789	200	175	225	B	3						
63790	80	55	225	B	3						
63791	100	75	225	B	3						
63792	125	100	225	B	3						
63793	160	135	225	B	3						
63794	200	175	225	B	3						
63795	250	225	225	B	3						
63796	300	275	225	B	3						
63797	350	325	225	B	3						
63798	400	375	225	B	3						
63799	80	55	225	B	3						
63800	100	75	225	B	3						
63801	125	100	225	B	3						
63802	160	135	225	B	3						
63803	200	175	225	B	3						
63804	300	275	225	B	3						
63805	80	55	225	B	3						
63806	100	75	225	B	3						
63807	125	100	225	B	3						
63808	160	135	225	B	3						
63809	200	175	225	B	3						
63810	250	225	225	B	3						
63811	125	100	225	B	3						
63812	160	135	225	B	3						
63813	200	175	225	B	3						
63814	250	225	225	B	3						
63815	300	275	225	B	3						
63816	160	125	225	B	3						
63817	160	150	225	B	3						
63818	160	160	225	B	3						

Untoleranced dimensions DIN ISO 2768 mean

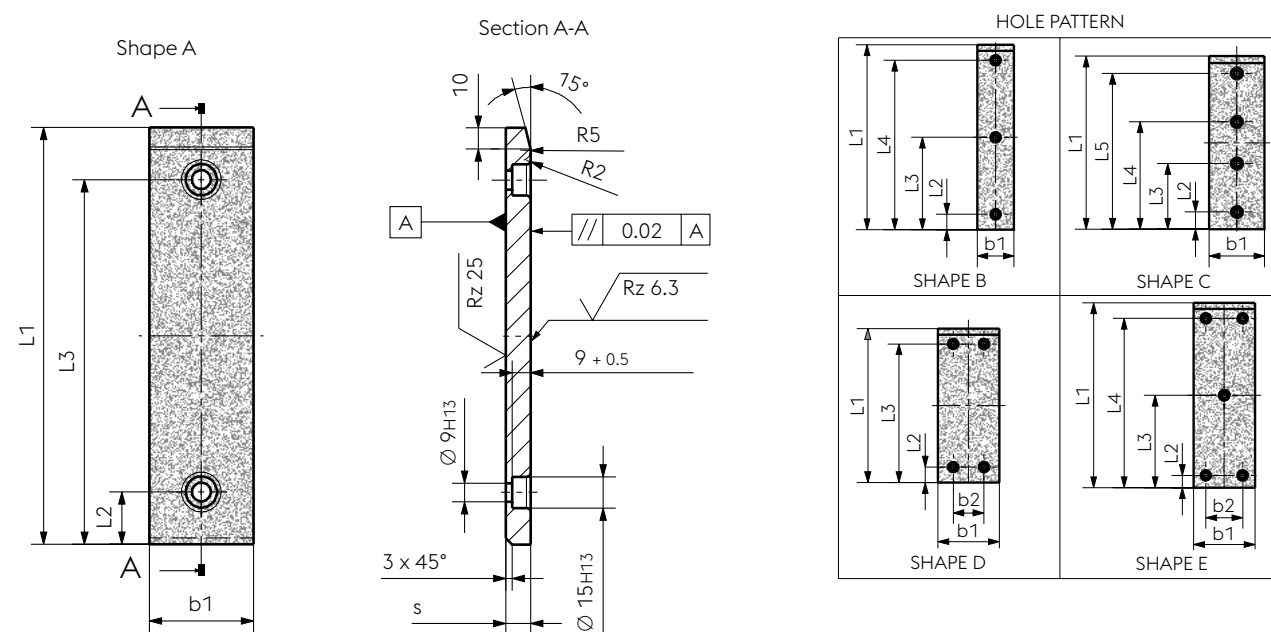

## Agencies abroad

### BRAZIL

**Oceantec Ltda.**  
Sao Paulo, Brasil  
T. +55 11/960 85-0022  
christian.bohm@oceantec.at

### CANADA / US

**Lacher Camtec Corp.**  
1907 Albion Road  
Toronto ON M9W 5S8, Canada  
T. +1/4165593345  
marlene.sturm@lacher-camtec.com  
T. +1/4166755150  
chuck.ciaravino@lacher-camtec.com

### CHINA

**NYC Industrial Co., Ltd.**  
No. 2501 people's road  
Jiashan County, Zhejiang  
nyc@lacher-camtec.com

### CZECH REPUBLIC

**E - Normalie servis s.r.o.**  
Rybna 716/24,  
110 00 Staré Město, Praha  
Czech Republic  
T. +420/566/521 436  
info@e-normalie.cz

### ITALY

**Maric S.A.S. di Rossato & C.**  
Via Milano 7  
23878 Verderio Superiore-LC, Italy  
T. +39/039/928 12-62  
F. +39/039/951 71-75  
maricas@maricas.com

### MEXICO

**Lacher Camtec Corp.**  
1907 Albion Road  
Toronto ON M9W 5S8, Canada  
T. +1/6477454592  
marlene.sturm@lacher-camtec.com

### NETHERLANDS / BELGIUM

**Technisch Büro Bäcker B.V.**  
Pieter Lieftinckweg 20  
1505 HX Zaandam, Netherlands  
T. +31/75/681 80 00  
info@tbbacker.nl

### SLOVAKIA

**E - Normalie servis s.r.o.**  
Rybna 716/24,  
110 00 Staré Město, Praha  
Czech Republic  
T. +420/566/521 436  
info@e-normalie.cz

### SOUTH AFRICA

**Tecno Design C.C.**  
P.O.Box 11021  
0161 Maroleana, South Africa  
T. +27/825742021  
tecno@icon.co.za

### SOUTH KOREA

**WonNetworks**  
GWANG JU Design Center  
[62355] 509Ho Columbus world 15,  
Pungyeongcheolgil-ro, Gwangsan-gu,  
Gwangju, Republic of Korea  
M. +82/10/4899-8681  
kwangwon.kim@lacher-camtec.com

**Lacher Camtec GmbH**  
Badweg 1  
4890 Frankenmarkt, Austria  
T. +43 (0) 7684 22333  
sales@lacher-camtec.com  
www.lacher-camtec.com

### SWEDEN / NORWAY

**FINLAND / DENMARK**  
**Lagermetall AB**  
Boskärsgatan 23  
702 25 Örebro, Sweden  
T. +46/19/20 96 60  
brons@lagermetall.se

### THAILAND / INDONESIA

**PT. Tool Box Indonesia**  
Jl. Samsung Raya Bizpark Building  
Jababeka InovationCenter Blok A. NO.20,  
Mekarmukti, Cikarang Utara, Kab. Bekasi,  
Jawa Barat, Indonesia [17530]  
T. +62/21-2851-8084  
T. +61/21-2851-8269  
toolboxindo@gmail.com

11/2025



## SINTER SLIDING ELEMENTS

Maximum productivity and  
minimum maintenance costs

FORMING TOMORROW

**LACHER  
CAM  
TEC**

Lacher Camtec GmbH  
www.lacher-camtec.com

**LACHER  
CAM  
TEC**

# TECHNICAL DETAILS

Easy maintenance, reliable use: the porous sinter metal layer is applied to a base plate of steel. This guarantees the high durability and strength of the sinter sliding elements. A further advantage: no maintenance measures are needed during use because a lubricant is added to the sinter metal layer. However, lubrication should be carried out before commissioning and after every cleaning.

Maximum speed	<b>70 m/min</b> (after initial lubrication and depending on the PV value)
Working temperature	<b>maximum 250°C</b> (depending on the lubricant) For a maximum service life, we recommend an average working temperature of +40 °C to +80 °C
Mating material	<b>Surface finish Rz ≤ 6.3 µm</b> At least 30 HRC harder than the sinter surface (sinter surface 60-100 HB)
Processing	<b>Generally possible</b> (drilling, grinding, cutting, ...)
PV value	<b>Dry: 1.63 N/mm² x m/s   Lubricated: 3.5 N/mm² x m/s</b>
Material of base plate	<b>Steel – CK45</b> (or equivalent)
Surface pressure	<b>120 N/mm² (static)</b>
Coefficient of friction	<b>Dry: 0.2   Lubricated: 0.1</b>
Lubricant	<b>Mobilgear 600XP 150</b>
Lubricant share	<b>15-20%</b>
Porosity	<b>18-23%</b>
Sliding direction	<b>length- and cross-wise</b>

! Do not use any agents with grease removers during cleaning, this can cause lasting damage to the sliding capacity.

## YOUR ADVANTAGES AT A GLANCE

- » Guaranteed high durability and long service life thanks to the combination of a sinter metal layer and steel base plate
- » Increased productivity on account of a high surface pressure
- » Easy processing of the sinter sliding elements because the base plate is of steel
- » Even surface of the sinter metal layer
- » High temperature resistance possible up to 250 °C (depending on the lubricant)
- » Cost savings due to the low maintenance work
- » No additional maintenance measures needed (except initial lubrication)
- » Quick and easy replacement when worn
- » Ideal for high speeds and a uniform application of force

Benefit from the advantages of our original voestalpine Camtec sinter sliding elements! Fast, professional and solution-oriented. The staff at voestalpine Camtec GmbH are here to help you. Ask for more information and advice: [sales@lacher-camtec.com](mailto:sales@lacher-camtec.com)

# SLIDING PLATES 7.14

20 MM THICK  
ACC. TO VDI 3357

Sinter Ident no.	L1 ± 0.2	b1	s -0.02	L2 ± 0.2	L3 ± 0.2	L4 ± 0.2	L5 ± 0.2	b2 ± 0.2	Shape	Cyl. screw DIN EN ISO 4762	Pc.		
63717	80	50	20	25	55				A	M8 x 25	2		
63718	100				75								
63719	125				100								
63720	160				135								
63721	200				175								
63722	250				85	165	225						
63723	300				105	195	275						
63724	350				125	225	325						
63725	400				145	255	375						
63726	450				165	285	425						
63727	500	175	325	475									
63728	50	80	20	40				30	B	M8 x 25	2		
63729	80				55								
63730	100				75								
63731	125				100								
63732	160				135								
63733	200				175								
63734	250				210								
63735	315				275								
63736	250				85	165	225						
63737	300				105	195	275						
63738	350	125	225	325									
63739	400	145	255	375									
63740	450	165	285	425									
63741	500	175	325	475									
63742	50	100	20	40				50	B	M12 x 25	4		
63743	80												
63744	100				75								
63745	125				100								
63746	160				135								
63747	200				175								
63748	250				210								
63749	315				275								
63750	450				165	285	425						
63751	500				175	325	475						
63820	250	85	165	225									
63821	300	105	195	275									
63822	350	125	225	325									
63823	400	145	255	375									
63824	250	85	165	225									
63825	300	105	195	275									
63826	350	125	225	325									
63827	400	145	255	375									
63752	50	125	20	40				75	C	M12 x 25	2		
63753	80												
63754	100				75								
63755	125				100								
63756	160				135								
63757	200				175								
63758	250				210								
63759	315				275								
63760	450				165	285	425						
63761	500				175	325	475						
63828	250	85	165	225									
63829	300	105	195	275									
63830	350	125	225	325									
63831	400	145	255	375									
63832	450	165	285	425									
63833	500	175	325	475									
63762	50	160	20	40				110	D	M12 x 25	4		
63763	80												
63764	100				75								
63765	125				100								
63766	160				135								
63767	200				175								
63768	250				210								
63769	315				275								

Untoleranced dimensions DIN ISO 2768 mean

